

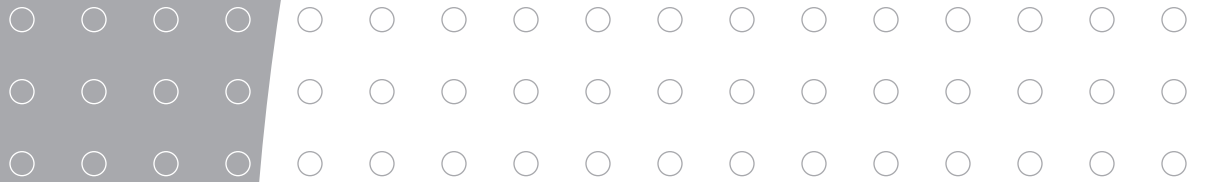

TELEGRA

Smart Traffic Management®



EMERGENCY ROADSIDE CALL SYSTEMS



Emergency Roadside Call Systems

When an accident occurs, a vehicle breaks down or another critical problem happens on the road, emergency communication capabilities aren't just desirable. They are absolutely essential. Even in the era of cell phones, emergency communication systems are still mandatory in many locations – particularly in tunnels and remote highways where cellular signals are either weak or unavailable.

Regardless of where your roads take you, Telegra has the answer you're looking for. We not only offer complete Emergency Roadside Call Systems (ERCS), our solutions are also crafted for the specific needs of highway and tunnel environments. Telegra ERCS solutions allow traffic managers to:

- » Assist motorists in distress
- » Obtain information regarding emergencies or hazardous conditions
- » Maintain safety on highways and in tunnels
- » Provide a highly visible and easy-to-locate apparatus for drivers to call for help
- » Provide emergency communication in remote areas
- » Utilize a central location to respond to and monitor calls from multiple calling devices

The safety of motorists on your highways and in your tunnels is essential at all times. Don't compromise it with anything less than an ERCS designed specifically for roadway applications – no matter how remote or inaccessible a location may seem.

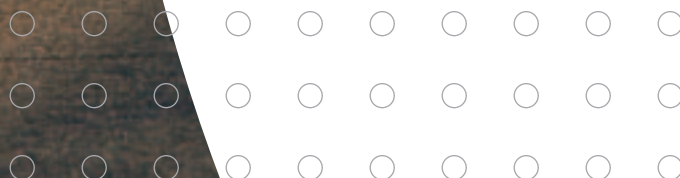

FAIL-SAFE COMMUNICATIONS FOR HIGHWAYS AND TUNNELS.

CALLING ALL SOLUTIONS

Telegra's ERCS solutions feature a variety of calling devices to meet the diverse requirements of roads and tunnels. Our products are:

- » Manufactured according to the highest technological standards
- » Crafted for reliability and endurance in the harshest conditions
- » Designed ergonomically for ease of use
- » Activated with a single large button
- » Available with SM fiber optic cable, Ether net or twisted copper wire (option available upon request)
- » Available using solar power with battery back-up, per customer requirements
- » Produced in kiosk and wall-mount models
- » Connected to a central call station
- » Standard VoIP protocol supported

COMMUNICATION DEVICES DESIGNED TO DRIVE SAFETY

CENTRAL CONTROL STATION

The main component of the Telegra ERCS is the Central Control Station (CCS), which functions as the interface between communications devices in the field and the public telephone network. A versatile, modular design allows roadway managers to configure the Telegra ERCS system according to their needs. Plus, fully digital architecture and DSP audio processing allows for superior sound quality.

The CCS is available in two types of Interfaces:

- Emergency Call System-Central Unit (ECS CU): PC software
- Emergency Call System-Desk Unit (ECS DU): A stand-alone handling desk

Depending on configuration, system reach can be from 25 to 100 miles with as many as 256 ERCS devices. Multiple configurations are also allowed, based on conditions, and can include SM fiber optic cable, Ether net or twisted copper wire.

Calling devices signal the CCS using a current modulation with one of 16 pre-defined and pre-programmed frequencies. A call detection system within the CCS recognizes the signal and receives the audio input.

CCS FEATURES

SM Fiber Execution

- » One main control board (96 TG 020)
- » Up to eight line modules
- » Two independent interfaces to the public telephone network
- » PC synchronization through an RS-232 interface
- » Connection for audio recording equipment
- » DSP technology for sound processing
- » Periodic auto testing of calling devices and notification of detected errors
- » Over-current and over-voltage protection
- » Network enclosure accommodating up to a 19" 6HE rack

Ethernet Execution

- » Workstation with proprietary soft switch application
- » Standard VoIP protocols supported
- » Connectivity through standard VoIP handsets

Twisted Copper Pair Execution

- » Connected to CS through the 96 TG 048C line module
- » Three twisted pairs, pupinized to 1200 Ohms
- » Modulating current on one of eight pre-defined and pre-programmed frequencies

EMERGENCY ROADSIDE CALL SYSTEM (ERCS)

Telegra's ERCS enables motorists to place emergency calls even from the most isolated roadways. Consisting of easy to use and highly visible communication kiosks, devices are available with SM fiber optic cable or twisted copper wire. The SM fiber optic option also includes a remote cabinet to power the devices and transmit messages. All units feature a rugged design to ensure reliability and low maintenance.

Emergency Roadside Call Kiosk (ERCK): SM Fiber

Telegra's solar powered SM fiber optic ERCK, in conjunction with battery backup, allows operation without remote powering and therefore extends ERCK system reach up to 100 miles. Features include:

- » Serial connection to the CCS via SM fiber optic cables in redundant loop
- » Two ERCS devices per one communication unit, one on each side of the road
- » Maximum 32 communication units (16 pairs)

Emergency Roadside Call Kiosk (ERCK):

Twisted Copper Pair

Designed for use when on-site power is available,

the ERCK with twisted copper pairs is manufactured according to the highest technology standards and provides total system reach of up to 25 miles. Components include:

ERCS CENTRAL UNIT BLOCK DIAGRAM

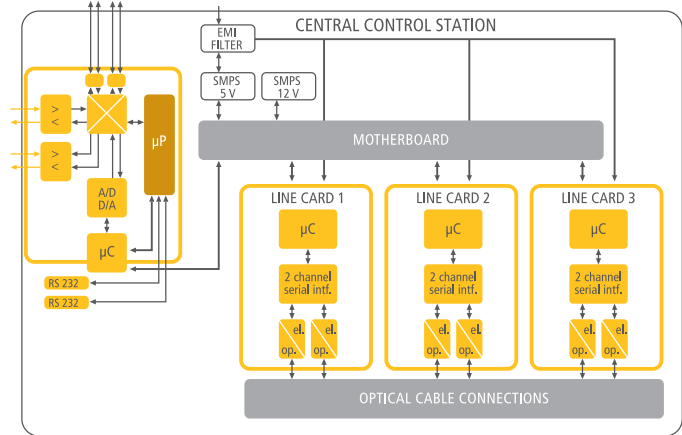

- » Three twisted pairs, phantom powered
- » Twisted pair 1 (pupinized): audio in / central station call detection
- » Twisted pair 2 (pupinized): audio out
- » Twisted pair 3: emergency call signaling to central station
- » Phantom power supply voltage applied between pair 1 and 2
- » Quartz PLL, MCU controlled technology

EMERGENCY ROADSIDE CALL KIOSK COMMUNICATION UNIT

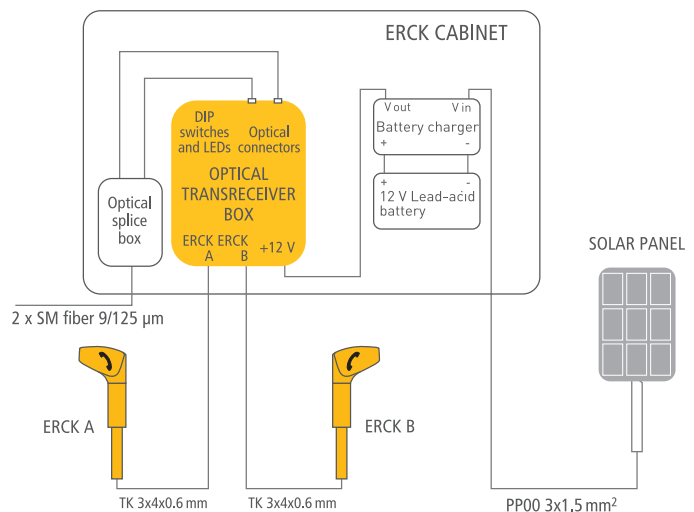

A cabinet contains an optical transmitter and a data and audio interface for two ERCK devices, and power supply is via a solar panel and battery system.

EMERGENCY TUNNEL CALL SYSTEM (ETCS)

Telegra also manufactures ERCS devices designed to address the specific challenges of tunnels. Telegra's ETCS includes two distinct Emergency Tunnel Call Boxes (ETCBs):



Surface Mount (ETCB-SM)

This unit is placed inside tunnels and is designed for noise abatement.

Flush Mount (ETCB-FM)

This unit is placed within tunnel escape routes, such as emergency stairwells, and is separated from the noise and traffic of the tunnel.

An ETCS cabinet houses the equipment necessary for transmitting and powering the call boxes. It contains an:

- » Optical transmitter
- » Data and audio interface for two ETCBs
- » Battery power supply

Two ETCBs, one on each side of the tunnel, are connected in a series to one communication unit via SM fiber optic cables or Ethernet, and two redundant full duplex serial loops are connected to a central control station. The result is a system that is resistant to first failure in any of the communication lines.

Other features include:



TUNNEL CALL UNIT BLOCK DIAGRAM

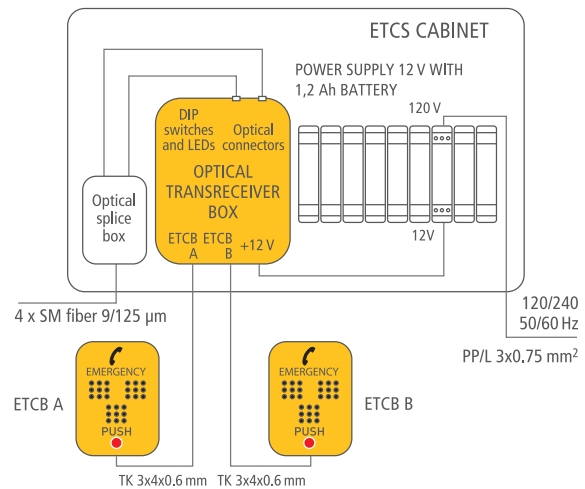

- » Ergonomic design for easy use with one large push button
- » Highly recognizable design for easy visibility
- » Operating range up to 100 miles
- » Maximum 16 communication units (32 ETCBs) in one optical telecommunication line
- » Low power consumption
- » Rugged design for durability and low maintenance

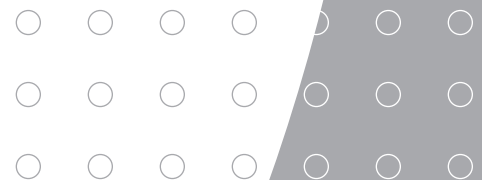

PRODUCT SPECIFICATIONS

EMERGENCY CALL SYSTEM CENTRAL CONTROL STATION	
Capabilities	Interface with up to 256 telephone stations; up to 8 line modules (SM Fiber, Ethernet or copper-based); linkage with 2 public telephone networks
Connection System Features	Fiber optic; Ethernet, twisted pair copper; RJ-45 jacks; DB-9 connector SM fiber optic lines: standard 9/125 SM fiber; ST connectorized; 4 (2) fibers per line Ethernet: standard VoIP protocols supported Copper lines: 3 twisted pairs, pupinized to 1200 Ohms; max 113 Ohms/mile per pair resistance; 14 pole connector type
Features	19" network rack; DSP sound processing technology; automatic testing and error reporting
Functionality	Ergonomically advanced central user interface of emergency roadside telephone stations
Handling Desk	14 pole connector type
Interface	PC interface via RS-232; audio recording interface
Message Alerts	Email; SMS; automatic; semi-automatic; manual
PC	DB-9 connector
Power Consumption	80 W maximum
Power Requirements	120/240 VAC-50/60 Hz @ 80 Watts
Power Supply	120/240 VAC-50/60 Hz
System Architecture	Full digital architecture
Telephone Lines	Two RJ-45 standard outlets
EMERGENCY ROADSIDE CALL KIOSK AND EMERGENCY TUNNEL CALL SYSTEM	
Electromagnetic Interference	Telegra ERCs meet electromagnetic interference immunity criteria for the following: ERCK unit meets electromagnetic interference immunity levels as defined in EN 50293:2000 EN 55022: terminal disturbance voltage, class: B EN 55022: radiated emissions, class: B EN 61000-3-2: limits for harmonic current emissions, class: A EN 61000-3-3: limitation and voltage fluctuations and flicker low voltage supply system EN 61000-4-2: immunity to electrostatic discharge; failure criteria: B EN 61000-4-3: immunity to radiated electromagnetic fields; failure criteria: A EN 61000-4-4: immunity to fast transients (burst); failure criteria: B EN 61000-4-5: immunity to surges; failure criteria: B EN 61000-4-6: immunity to conducted high frequency interference; failure criteria: A EN 61000-4-11: immunity to voltage drops, short interruptions and voltage variations
Operating Temperature Range	-22° to +158° F
EMERGENCY ROADSIDE CALL KIOSK SM FIBER AUDIO SPECIFICATIONS	
Audio Encoding	7.2 kHz
Frequency Response	300-3200 Hz
Sampling Frequency	12 bits, PCM
Speaker Audio Output Power	0.7 W
EMERGENCY ROADSIDE CALL KIOSK SM FIBER DC ELECTRICAL SPECIFICATIONS	
Battery Capacity	24 Ah
Duration of Operation	480 hours (fully charged battery without recharging)
Supply Current (active)	30-70 mA
Supply Current (standby)	2.5-4 mA
Supply Voltage	10-25 VDC
EMERGENCY ROADSIDE CALL KIOSK SM FIBER OPTICAL SPECIFICATIONS	
Cable Type	9/125 single mode
Connector Type	ST, or user selectable
Coupled Optical Power, Single Mode	0.3 mW
Link Distance	12 miles
No. of Fibers	4 (2)
Optical Budget	17 dB

PRODUCT SPECIFICATIONS (continued)

EMERGENCY ROADSIDE CALL KIOSK (SM FIBER AND COPPER WIRE) MECHANICAL SPECIFICATIONS	
Dimensions	64" high x 16" wide x 20" deep (without solar panel)
Pushbutton Type	PIEZO, hermetically sealed
Weight	116 pounds (kiosk)
EMERGENCY ROADSIDE CALL KIOSK COPPER WIRE AC SPECIFICATIONS	
Audio Frequency Response	300-3300 Hz
Audio Input Level for Central Station Call Detection	-44 dBm
Central Station Call Frequency Range	704-2699 Hz
Current Modulation, ERT Call Signal	1.0 mA
Input and Output Level Adjustable Range	10 dB
Line Input Level for Output Power	-6 dBm
Line Output Level	-3 dBm
Maximum Allowable Central Station Call Frequency Deviation	3%
Maximum ERT Call Signal Frequency Deviation	0.1%
Speaker Audio Output Power	0.25W
EMERGENCY ROADSIDE CALL KIOSK COPPER WIRE DC ELECTRICAL SPECIFICATIONS	
Supply Current (active)	0.9-3 mA
Supply Current (standby)	0.6-2 mA
Supply Voltage	15-48 VDC
EMERGENCY TUNNEL CALL SYSTEM SM FIBER AUDIO SPECIFICATIONS	
Audio Encoding	7.2 kHz
Frequency Response	300-3200 Hz
Sampling Frequency	12 bit, PCM
Speaker Audio Output Power	0.7W
EMERGENCY TUNNEL CALL SYSTEM SM FIBER ELECTRICAL SPECIFICATIONS	
Battery Capacity	1.2 Ah
Duration of Operation (fully charged battery without recharging)	24 hours
Supply Current	10 mA
Supply Voltage	230 VAC
EMERGENCY TUNNEL CALL SYSTEM (SM FIBER AND ETHERNET) MECHANICAL SPECIFICATIONS	
Dimensions	12" high x 8" wide x 6" deep
Emergency Call Pushbutton Type	PIEZO, mechanical
Weight	9 pounds
EMERGENCY TUNNEL CALL SYSTEM SM FIBER OPTICAL SPECIFICATIONS	
Cable Type	9/125 single mode
Connector Type	ST, or user selectable
Coupled Optical Power (single mode)	0.3 mW
Link Distance	12 miles
Number of Fibers	4
Optical Budget	17 dB
EMERGENCY TUNNEL CALL SYSTEM ETHERNET AUDIO SPECIFICATIONS	
Audio Encoding	G.711, G.729a (option), 64/128 kbps
Frequency Response	300-3600 Hz
Latency	10/20 ms
Echo Cancellation	32 ms delay (switchable ON/OFF)
Speaker Audio Output Power	0.7 W
EMERGENCY TUNNEL CALL SYSTEM ETHERNET DC ELECTRICAL SPECIFICATIONS	
Supply Current (active)	200 mA
Supply Current (standby)	120 mA
Supply Voltage	10-25 VDC

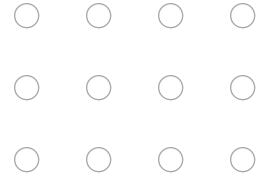

CERTIFICATIONS

Telegra's ERCS products are UL and CUL listed as well as FCC compliant. They exceed all international standards for the most stringent mechanical and environmental requirements. The products comply with:

- » ISO 9001:2000 certification
- » EN 55022
- » EN 61000-4-5
- » EN 61000-3-2
- » EN 61000-3-3
- » EN 61000-4-11
- » EN 55024
- » EN 6100-4-2
- » EN 61000-4-6
- » EN 61000-4-3
- » EN 61000-4-4



American Welding Association | ISO 9001:2000 Certification

Telegra is a member of AAAE, AASHTO, ATSSA, IBTTA, IEEE, IMSA, IRF, ITE, ITS America, NEMA, TEAM Florida, TEAM Texas and TRB



TELEGRA
Smart Traffic Management®

3030 LBJ FREEWAY • SUITE 1385 • DALLAS, TEXAS 75234
1.877.282.3535 • PHONE 972.241.3535 • FAX 972.241.3541 • info@telegra-inc.com • www.telegra-inc.com